

FICHE TECHNIQUE

TECHNICAL SHEET



QUANTICA 650



CARACTÉRISTIQUES TECHNIQUES

CONCEPTION	Corps en fonte d'aluminium, verre plat trempé, résistance aux chocs IK 08
FINITION	Peinture polyester selon nuancier RAL
PROTECTION	IP66
ISOLATION	Classe 1 ou 2
FIXATION	Montage latéral : tube \varnothing 60 mm / Montage en top : tube \varnothing 60 - 76 mm / Montage sommital : PG 27 mâle

DIMENSIONS, POIDS, PUISSANCE

DIMENSIONS	En top : 790 x 180 mm Suspendu : \varnothing 650 x 180 mm Latéral : 745 x 180 mm
POIDS	10 - 11,5 kg
NOMBRE DE LED	32 - 48 - 60
PUISSANCE LED	34 - 199 W

TECHNICAL CHARACTERISTICS

CONCEPTION	Die cast aluminium body, flat hardened glass, shock resistance IK 08
FINISH	Polyester paint according to RAL color chart
PROTECTION	IP66
INSULATION	Class 1 or 2
FIXING	Side fixing assembly : \varnothing 60 male pipe / On top assembly : 60 - 76 male pipe / Hanging assembly : Male 27 PG

SIZE, WEIGHT, WATTAGE

SIZE	On top : 790 x 180 mm Hanging : \varnothing 650 x 180 mm Side : 745 x 180 mm
WEIGHT	10 - 11,5 kg
NUMBER OF LED	32 - 48 - 60
LED WATTAGE	34 - 199 W

CURVED POLE / MÂT INCURVÉ

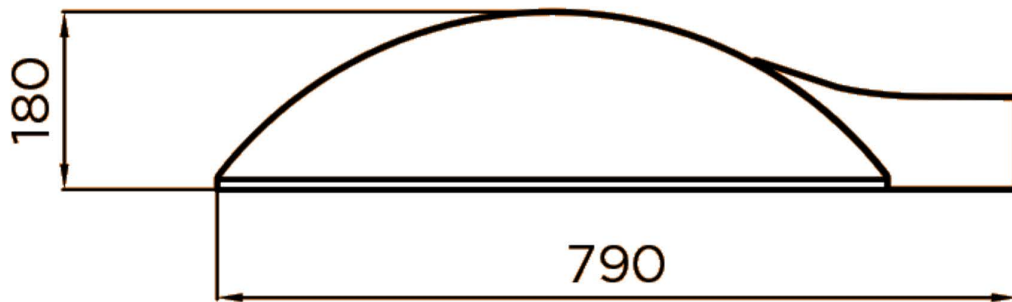

SUSPENDED / SUSPENDUE

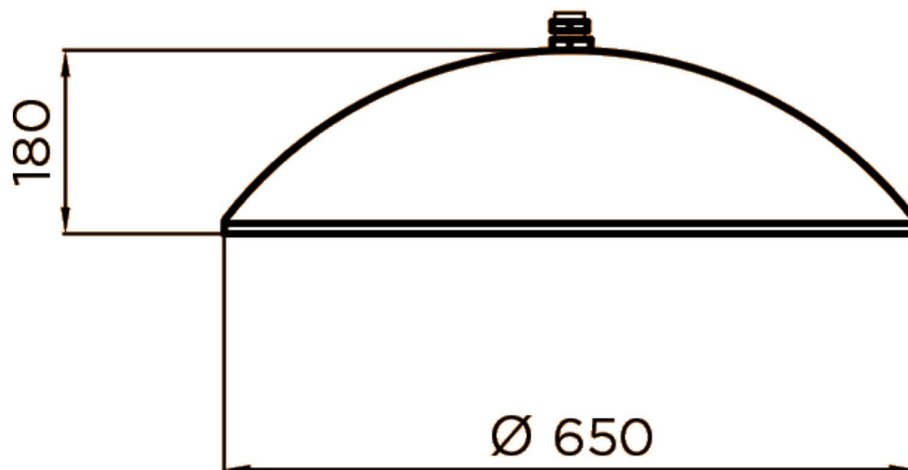

LAYING MOUNTED / LATERAL

